

# AIR GAGE DISPLAY

## PART NO. 9408-QD100

DATA  
OUTPUT

- Can store 10 measuring programs, and the program can be switched quickly
- Data storage function, support manual and automatic storing, 1500 groups data can be stored



air filter (optional)



pressure regulating valve (optional)



RS485 cable (optional)

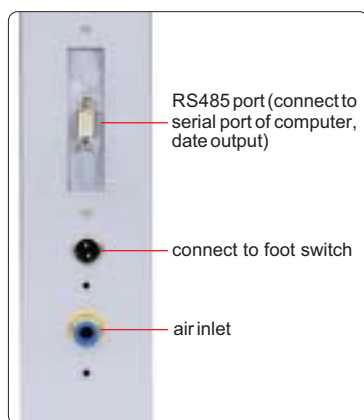

back of display



foot switch (optional)

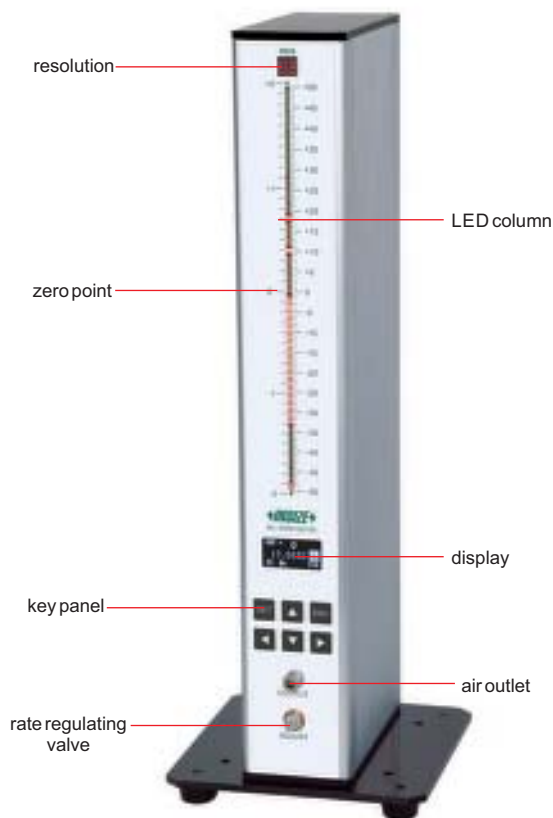

### SPECIFICATION

LED quantity	101 pcs			
LED color	red, orange, green			
LED height	254mm			
Range, resolution and accuracy	range	resolution		accuracy
		LED	display	
	10 $\mu$ m	0.1 $\mu$ m	0.1 $\mu$ m	0.2 $\mu$ m
	20 $\mu$ m	0.2 $\mu$ m	0.1 $\mu$ m	0.4 $\mu$ m
	50 $\mu$ m	0.5 $\mu$ m	0.1 $\mu$ m	1 $\mu$ m
	100 $\mu$ m	1 $\mu$ m	0.1 $\mu$ m	2 $\mu$ m
Unit	mm, $\mu$ m			
Air supply	dry and clean, 58-116 psi			
Data interface	RS485			
Operation temperature	-4~113°F			
Power supply	110~220V, 50/60Hz			
Dimension (L×W×H)	7.87×7.08×19.29"			
Weight	9.92lb			

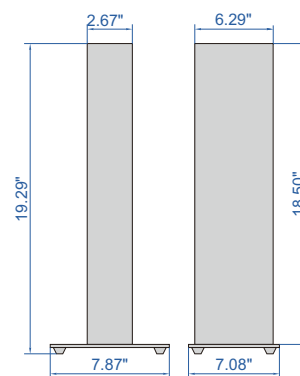

### STANDARD DELIVERY

Main unit	1 pc
-----------	------

### OPTIONAL ACCESSARY

Air filter	9401-FILTER-A
Pressure regulating valve	9404-PRV
RS485 cable	9408-CB
Foot switch	9408-FS
Data output cable (keyboard format)	7302-9408