

# FORKLIFT SCALES

- Zero-setting, subtracting tare value, counting, check weighing
- Automatic screen off, automatic power off
- Low voltage indication, overload indication
- Weight hold, weight totalisation, percentage display
- LED large screen display
- Unit: kg, lb



LED indicator



8801-A20

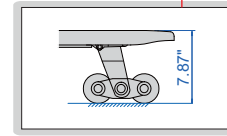
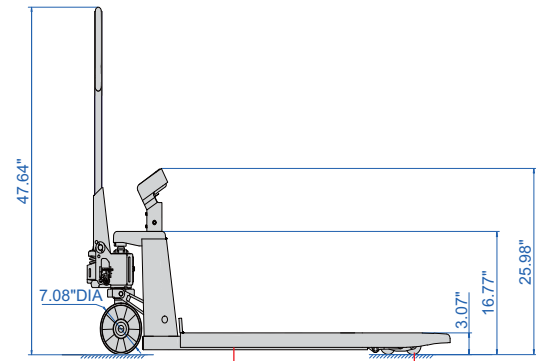

maximum lifting height

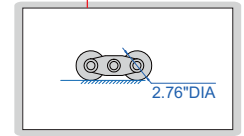

diameter of rear wheels

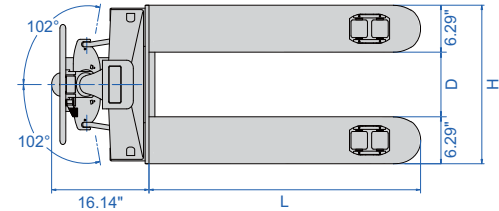

## SPECIFICATION

Part No.	8801-A15	8801-A20	8801-A25	8801-B15	8801-B20	8801-B25
Maximum weighting	1500kg/3300lb	2000kg/4400lb	2500kg/5500lb	1500kg/3300lb	2000kg/4400lb	2500kg/5500lb
Minimum weighting	10kg/22lb	20kg/44lb	20kg/44lb	10kg/22lb	20kg/44lb	20kg/44lb
Resolution	0.5kg/1lb	1kg/2lb	1kg/2lb	0.5kg/1lb	1kg/2lb	1kg/2lb
Accuracy	±1kg/±2lb	±1kg/±2lb	±2kg/±4lb	±1kg/±2lb	±1kg/±2lb	±2kg/±4lb
Forklift arm length (L)	45.28"			48.03"		
Forklift arm distance (D)	8.67"			14.17"		
Overall forklift width (H)	21.26"			26.77"		
Weight	216.05lb			231.49lb		
Material	mild steel					
Indicator power supply	rechargeable lead acid battery(6V/4Ah)					
Operation temperature	14~122°F					
Operation humidity	30%~90%RH					
Limited load	2500kg/5500lb	3000kg/6600lb	3000kg/6600lb	2500kg/5500lb	3000kg/6600lb	3000kg/6600lb