

**IP65**  
WATERPROOF

## ELECTRONIC CRANE SCALES

- Dust/waterproof level: IP65
- LED display, remote control
- Low voltage indicator
- Unit: lb, kg
- Overload alarm
- Automatic power off
- Aluminum alloy die casting case with high strength
- 360° safe rotary hook and shackle

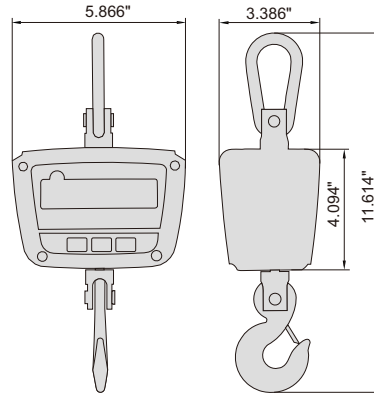

Remote controller  
(included)



8201-150KG

### SPECIFICATION

Part No.	8201-50KG	8201-150KG	8201-300KG
Maximum weighing	110lb	330lb	660lb
Minimum weighing	1lb	2lb	4lb
Resolution (d)	.05lb/.02lb	.10lb/.05lb	.20lb/.10lb
Verification interval (e)	.05lb	.10lb	.20lb
Accuracy	±.05lb	±.10lb	±.20lb
Operating temperature	14~104°F		
Operating humidity	30%~90% RH		
Overload alarm	100%F.S.+9e		
Maximum safe load	125%F.S.		
Limited overload	400%F.S.		
Power supply	rechargeable battery 6V/3Ah (for 40 hours working)		
Stable reading time	≤8s		

### STANDARD DELIVERY

Main unit	1 pc
Remote controller	1 pc
Battery charger	1 pc