

# PRECISION UNIVERSAL VISE

- Horizontal rotary: range 360°, graduation 0.05°
- Vertical incline: range 45°, graduation 0.05°
- With incline adjust knob
- Parallelism and squareness between A, B, C and D: 50µin/per inch, parallelism between D and E at 0°: 100µin/per inch
- Made of tool steel
- Hardness HRC56-58

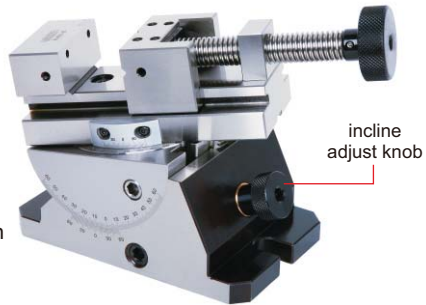

6521-80

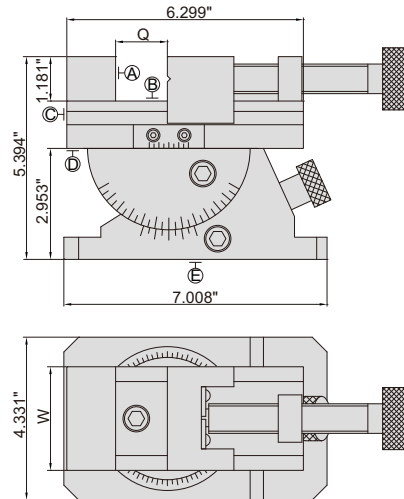

Part No.	Jaw opening (Q)	Jaw width (W)
6521-80	0-3.1"	2.756"