

# CONCENTRICITY GAGES

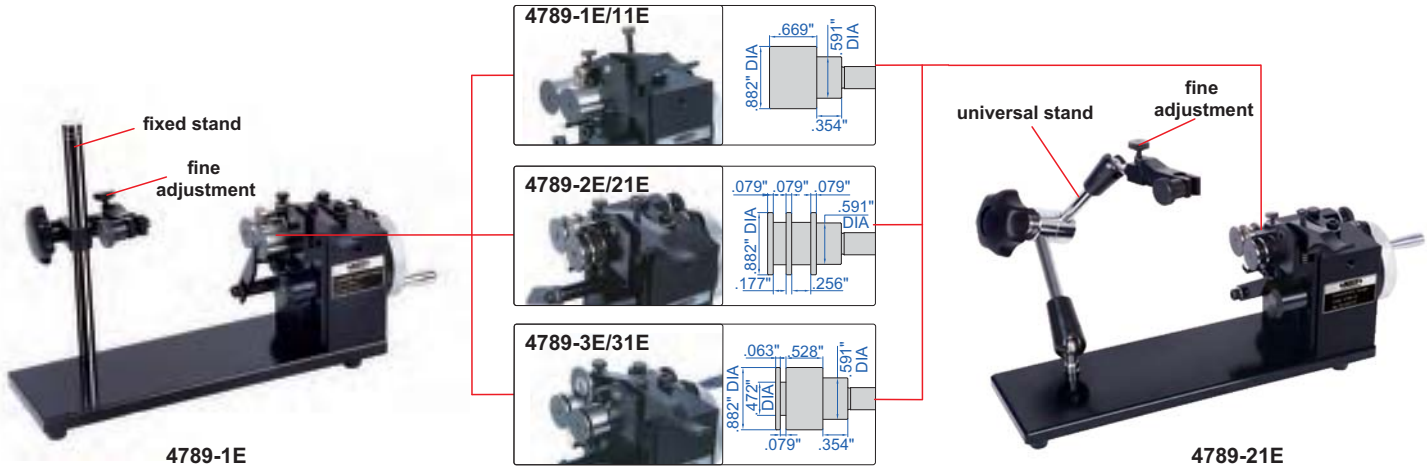

- Accuracy .00008"
- Optional accessory: dial test indicator

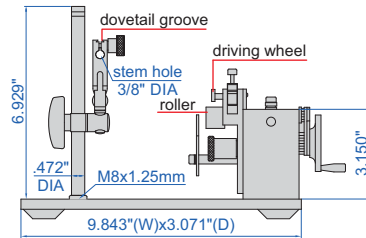

**4789-1E**

to ensure the accuracy .00008", the distance between measuring point and roller should be <math>< 1.181''</math>

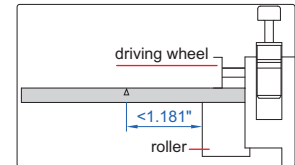

Part No.	Applicable diameter	Remark
4789-1E	.138" DIA- .984" DIA	fixed stand, high accuracy, inconvenient operation
4789-2E	.039" DIA- .984" DIA	fixed stand, high accuracy, inconvenient operation
4789-3E	.039" DIA- .984" DIA	fixed stand, high accuracy, inconvenient operation
4789-11E	.138" DIA- .984" DIA	universal stand, low accuracy, convenient operation
4789-21E	.039" DIA- .984" DIA	universal stand, low accuracy, convenient operation
4789-31E	.039" DIA- .984" DIA	universal stand, low accuracy, convenient operation