

CONCENTRICITY GAUGES

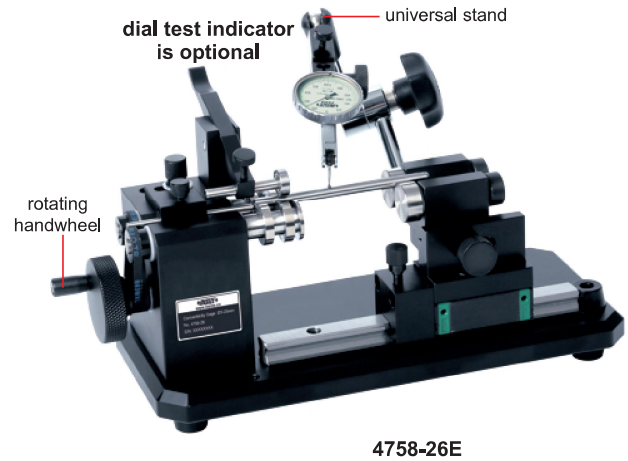

- Adjustable height tailstock: 0-.236", suitable for stepped cylindrical workpieces
- Optional accessory: dial test indicator

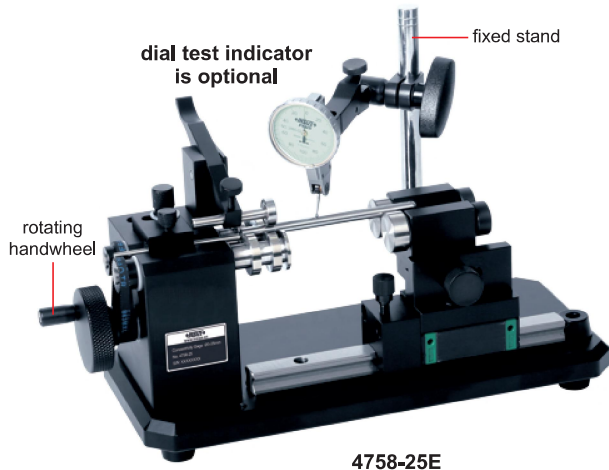
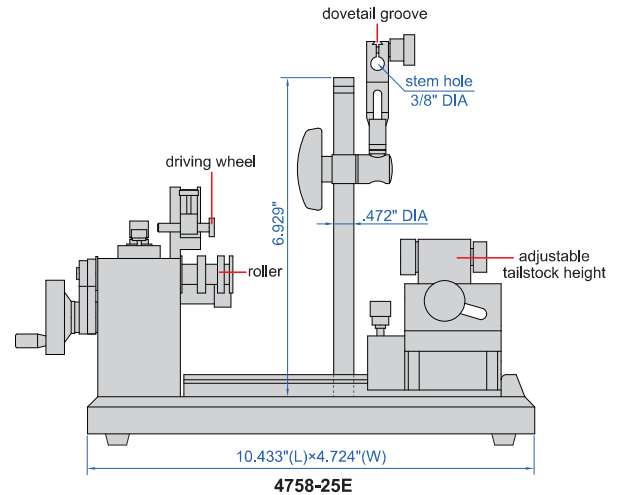

Part No.	Diameter range	Workpiece length	Accuracy	Net weight	Remark
4758-25E	.118-.984" DIA	.591"-5.984"	.00008"	8.2lb	fixed stand, high rigidity
4758-26E	.118-.984" DIA	.591"-5.984"	.00008"	8.2lb	universal stand, convenient operation