

GEAR ROOT DIAMETER MICROMETERS

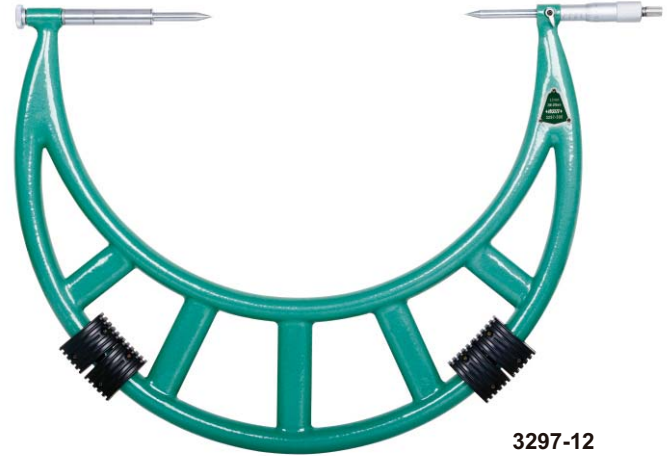

3297-4



3297-12

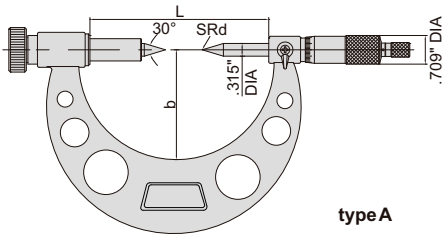

type A

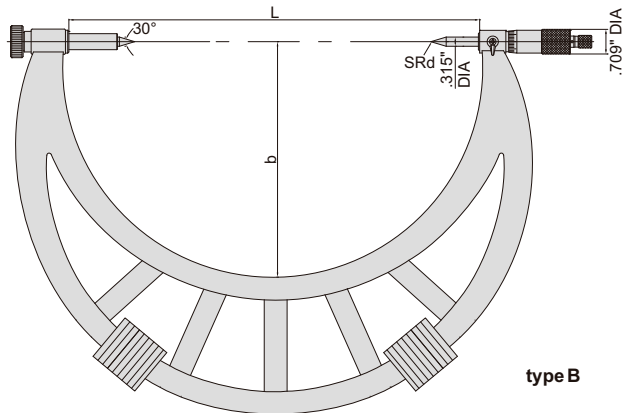

type B

- Measure diameter of gear root circle
- Graduation .001"
- Ratchet stop
- Carbide measuring faces
- Supplied with setting standards

Part No.	Range	Type	Accuracy	L	b	SRd
3297-4	0.2-4"	A	.00020"	5.394"	2.835"	.016"
3297-8	4-8"	A	.00028"	9.331"	5.079"	.016"
3297-12	8-12"	B	.00035"	16.300"	8.859"	.028"
3297-16	12-16"	B	.00043"	20.236"	10.827"	.028"
3297-20	16-20"	B	.00051"	24.173"	12.795"	.028"
3297-24	20-24"	B	.00055"	28.110"	14.764"	.028"
3297-28	24-28"	B	.00063"	32.047"	16.732"	.028"
3297-32	28-32"	B	.00071"	35.984"	18.701"	.028"
3297-36	32-36"	B	.00079"	39.921"	20.669"	.028"