

dial comparator  
is optional

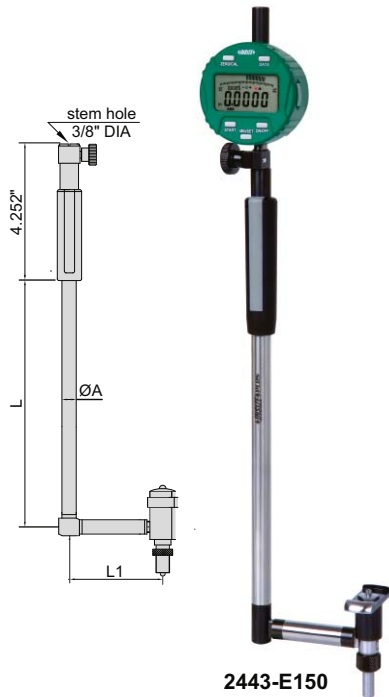

- Applicable for .001" or .0001" or .00005" graduation dial indicators
- Carbide contact points
- Optional accessory: setting ring (part no. **6313**), bore gage setter

Part No.	Range	Accuracy (without dial comparator)	Repeatability (without dial comparator)	ØA (DIA)	L	L1
<b>2443-E6 *</b>	.177-.236"	157µin	39µin	.157"	3.150"	1.181"
<b>2443-E8 *</b>	.236-.315"	157µin	39µin	.197"	3.937"	1.181"
<b>2443-E12 *</b>	.315-.427"	157µin	39µin	.197"	3.937"	1.181"
<b>2443-E20 *</b>	.427-.787"	157µin	39µin	.315"	4.331"	2.047"
<b>2443-E35 *</b>	.787-1.378"	157µin	39µin	.315"	4.331"	2.047"
<b>2443-E60 *</b>	1.378-2.362"	157µin	39µin	.472"	6.969"	2.441"
<b>2443-E100 *</b>	1.969-3.937"	157µin	39µin	.472"	6.969"	2.441"
<b>2443-E150 *</b>	1.969-5.906"	157µin	39µin	.472"	6.969"	2.441"
<b>2443-E160 *</b>	3.937-6.299"	157µin	39µin	.709"	9.213"	2.953"
<b>2443-E230 *</b>	3.937-9.055"	157µin	39µin	.709"	9.213"	2.953"
<b>2443-E290 *</b>	6.299-11.417"	157µin	39µin	.709"	9.213"	2.953"
<b>2443-E360 *</b>	6.299-14.173"	157µin	39µin	.709"	9.213"	2.953"
<b>2443-E410 *</b>	11.024-16.142"	197µin	87µin	.945"	15.748"	3.150"
<b>2443-E510 *</b>	11.024-20.079"	197µin	87µin	.945"	15.748"	3.150"
<b>2443-E800 *</b>	15.748-31.496"	197µin	87µin	.945"	15.748"	3.150"

\* Supplied with manufacturer inspection certificate traceable to NIST USA