

BACK PLUNGER TYPE DIAL INDICATOR

handle can be removed



- Supplied with handle
- Optional accessory: contact points (page 73)

points (included)

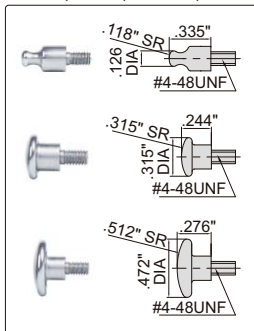

2320-02

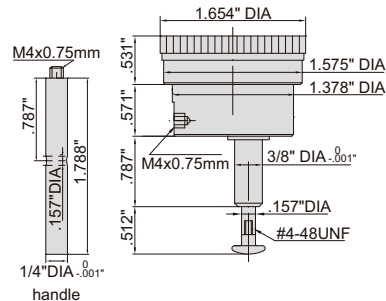

Part No.	Range	Graduation	Accuracy	Hysteresis	Range/rev	Dial reading
2320-02 *	.2 "	.001"	±.001"	.00033"	.1"	0-100

* Supplied with manufacturer inspection certificate traceable to NIST