

DIGITAL HEIGHT GAGES

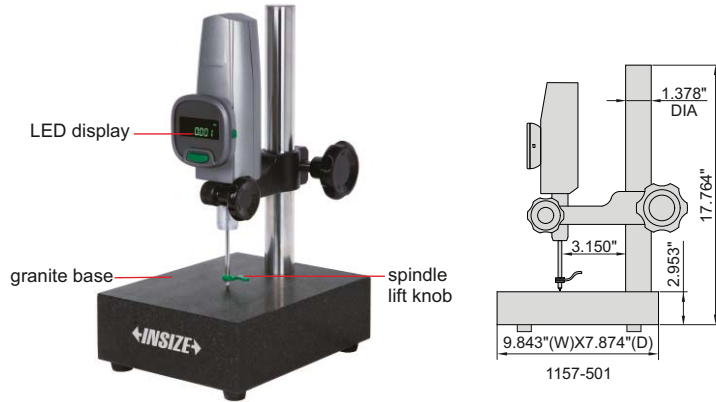

1157-501

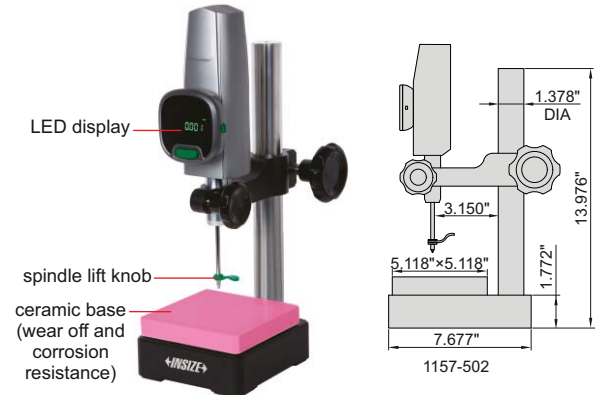

1157-502

measuring tips (included)

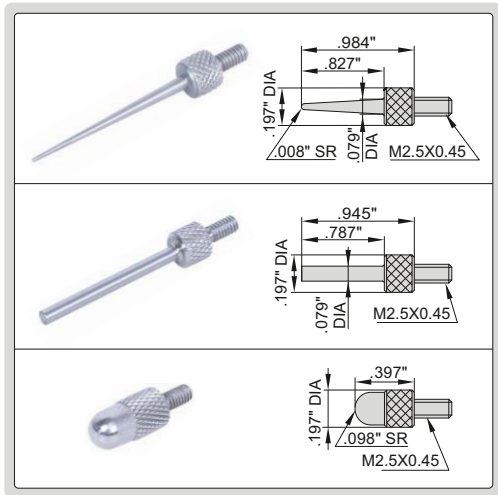

power supplied by charge pal



data transmitted to Excel without software;
short press the foot switch to transmit data,
long press to zero

- Buttons: on/off, zero, mm/inch, mix/min/mix-min
- High response speed (200"/s)
- High brightness LED display

Part No.	Range	Resolution	Accuracy (68°F)	Measuring force	Output	Power supply	Base
1157-501	0~2"	.00005"/1μm	118μin	.18lbf~.27lbf	USB	5V/1A (adapter or charge pal)	granite (flatness: 78μin)
1157-502	0~2"	.00005"/1μm	118μin	.18lbf~.27lbf	USB	5V/1A (adapter or charge pal)	ceramic (flatness: 39μin)

OPTIONAL ACCESSORY

STANDARD DELIVERY

Main unit	1 pc
-----------	------

Contact point	part no. 6282
Charge pal	1155-5-POB
Data output cables (including foot switch)	1155-5-FOS