

DIGITAL HEIGHT GAGES (ECONOMIC TYPE)

DATA
OUTPUT

- Resolution .0005"/0.01mm
- Buttons: on/off, zero, inch/mm, ABS/INC, data hold, TOL, set
- ABS/INC is for absolute and incremental measurement
- TOL is for tolerance measurement
- Carbide tipped scriber
- Made of stainless steel (except the base)
- LR44 battery, data output
- Supplied with dial test indicator holder
- Supplied with dust cover (except **1150-1500E/2000E**)
- Optional accessory: wireless transmitter (part no. **7315-1150**), data output cable (part no. **7302-SPC7**, keyboard format), data output cable (part no. **7305-R1150**, serial port format), clamp for protractors (part no. **2372-CLAMP**, for **1150-300E**)

scriber (included)

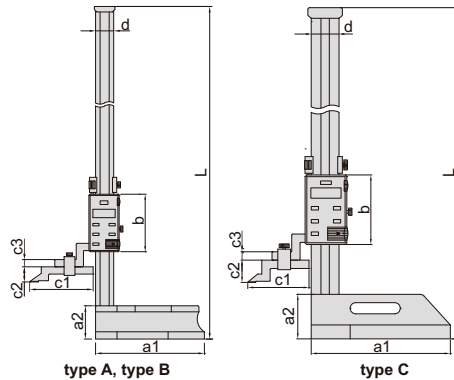
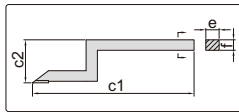

1150-300E

1150-500E

1150-1000E

dial test indicator holder (included)

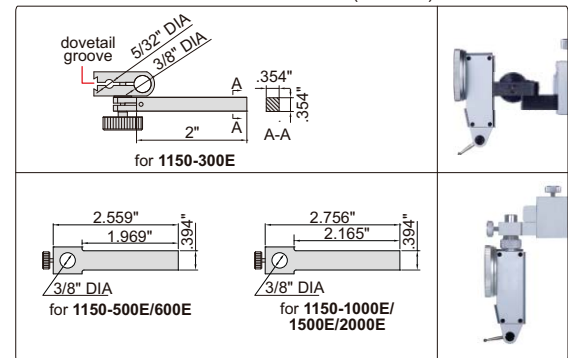

clamp for protractors (optional)
for 1150-300E

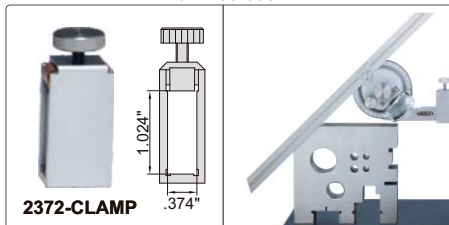

2372-CLAMP

Part No.	Range	Type	Accuracy	L	a1	a2	b	c1	c2	c3	d	e	f
1150-300E	0-12"/0-300mm	A	±.0015"	19.094"	5.433"	1.772"	3.740"	3.150"	1.181"	.394"	1.102"	.354"	.354"
1150-500E	0-20"/0-500mm	B	±.0025"	28.346"	7.087"	2.165"	3.740"	4.055"	.984"	.472"	1.181"	.394"	.472"
1150-600E	0-24"/0-600mm	B	±.0025"	32.283"	7.087"	2.165"	3.740"	4.055"	.984"	.472"	1.181"	.394"	.472"
1150-1000E	0-40"/0-1000mm	C	±.0030"	50.197"	9.843"	3.150"	4.921"	4.331"	1.535"	.591"	1.969"	.394"	.591"
1150-1500E	0-60"/0-1500mm	C	±.0050"	70.472"	11.024"	3.150"	4.921"	4.331"	1.535"	.591"	1.969"	.394"	.591"
1150-2000E	0-80"/0-2000mm	C	±.0065"	90.157"	11.024"	3.150"	4.921"	4.331"	1.535"	.591"	1.969"	.394"	.591"